



**HANDS-ON
CONTROL**

AUXILIARY HAND CONTROLS

The Kongsberg Automotive Vernier Control is the premium mechanical control for setting engine RPM, controlling regulating valves or for other precise remote adjustments. This latest design offers a larger grip for easier feel and two internal ball-bearings for smoother adjustment.

Applications for the Vernier Control range from generator sets, to manual throttles for warm up, on a wide variety of on and off-road vehicles.



AT A GLANCE

- Fast and Simple Installation - can be mounted independently to the dash and then connected to the cable on the other side of dash or firewall.
- Coarse Adjustment - depress top of grip and pull the Vernier knob out until an approximate rpm or setting is achieved.
- Fine Adjustment - rotate Vernier knob for precise adjustment
- Adjustable Brake - accurate settings can be maintained through vibration or governor back pressure by setting the correct amount of friction on the brake.
- Fast Shutdown - simply depress top of grip and simultaneously push in the knob for immediate shutdown.
- Recommended for loads up to 20 lbs.
- 3" cable travel. Travel can be reduced using stop collar.

PRODUCT RANGE AND SPECIFICATIONS

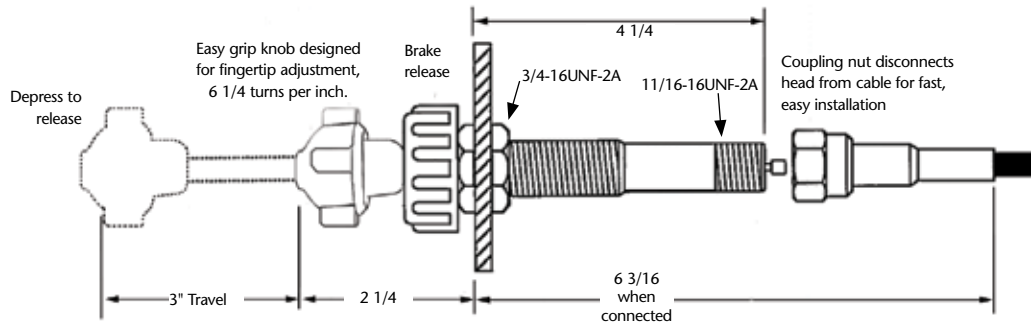

Series Description	End Type	Cable Series Part Number (cable only)	Cable Series Part Number (cable w/head)	Min. Bend Radius	"A"	"B"	"C"	"D"	"E" Dia.	"F" Dia.	"G" Thread UNF-2A
30L	Open	307141	317341	6"	-	-	-	-	.26	-	-
30L	Bulkhead	307142	317342	6"	-	-	1.88	1.00	.26	.38	-
30L	Clamp	307143	317343	6"	-	-	1.31	-	.26	.38	-
30	Bulkhead	307144	317344	8"	8.88	5.00	1.44	.88	.26	.44	.187-32
30	Clamp	307145	317345	8"	8.19	4.31	1.13	.88	.26	.38	.187-32
40	Bulkhead	307146	317346	8"	9.13	5.13	1.76	1.00	.43	.62	.250-28
40	Clamp	307147	317347	8"	8.50	4.50	1.38	1.00	.43	.56	.250-28

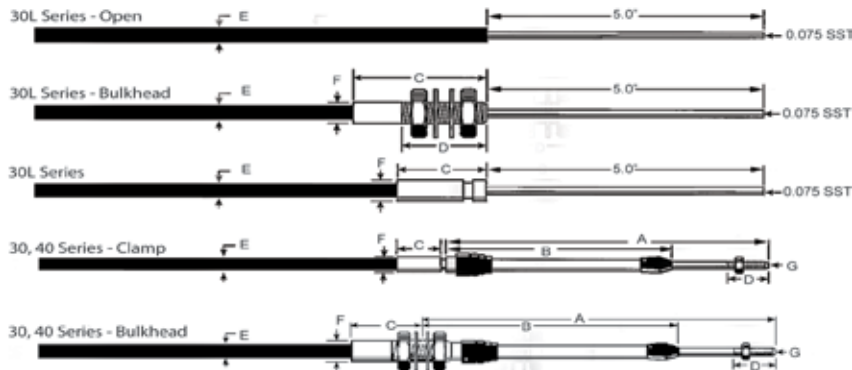

Vernier Hardware and Accessories	Part Number
30L Stop Collar	037693
30L Clamp	043229
30L Pivot	047639
30L Pivot	047640
30L Pivot	047641
30L Bulkhead Adapter Kit	300673
30L Clamp Adapter Kit	302485
30C Clamp to Bulkhead Kit	304307
40C Clamp to Bulkhead Kit	304308
Control Head	317310

Measuring and Ordering

- Cable length stamped on the cable is the overall length that is achieved when the vernier control head is attached to the cable.
- All L-type cables are measured to the point where the core wire exits the cable conduit.
- Cables with rod-type end fittings are measured to the rod end.
- A Quick Release Vernier Control can be ordered as two separate items. Use part number 317310 for the Vernier Control Head. Then order the desired cable part number, immediately followed by the desired cable length expressed in inches (order in 1 ft. increments.) Cables over 20 ft. are special order.

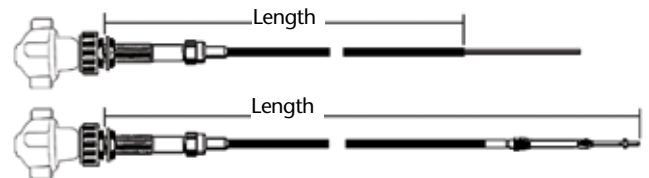

PART NUMBERING SYSTEM

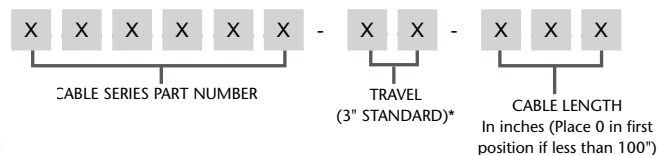

KONGSBERG
AUTOMOTIVE